

Omnie Pack 1 Installation Guide

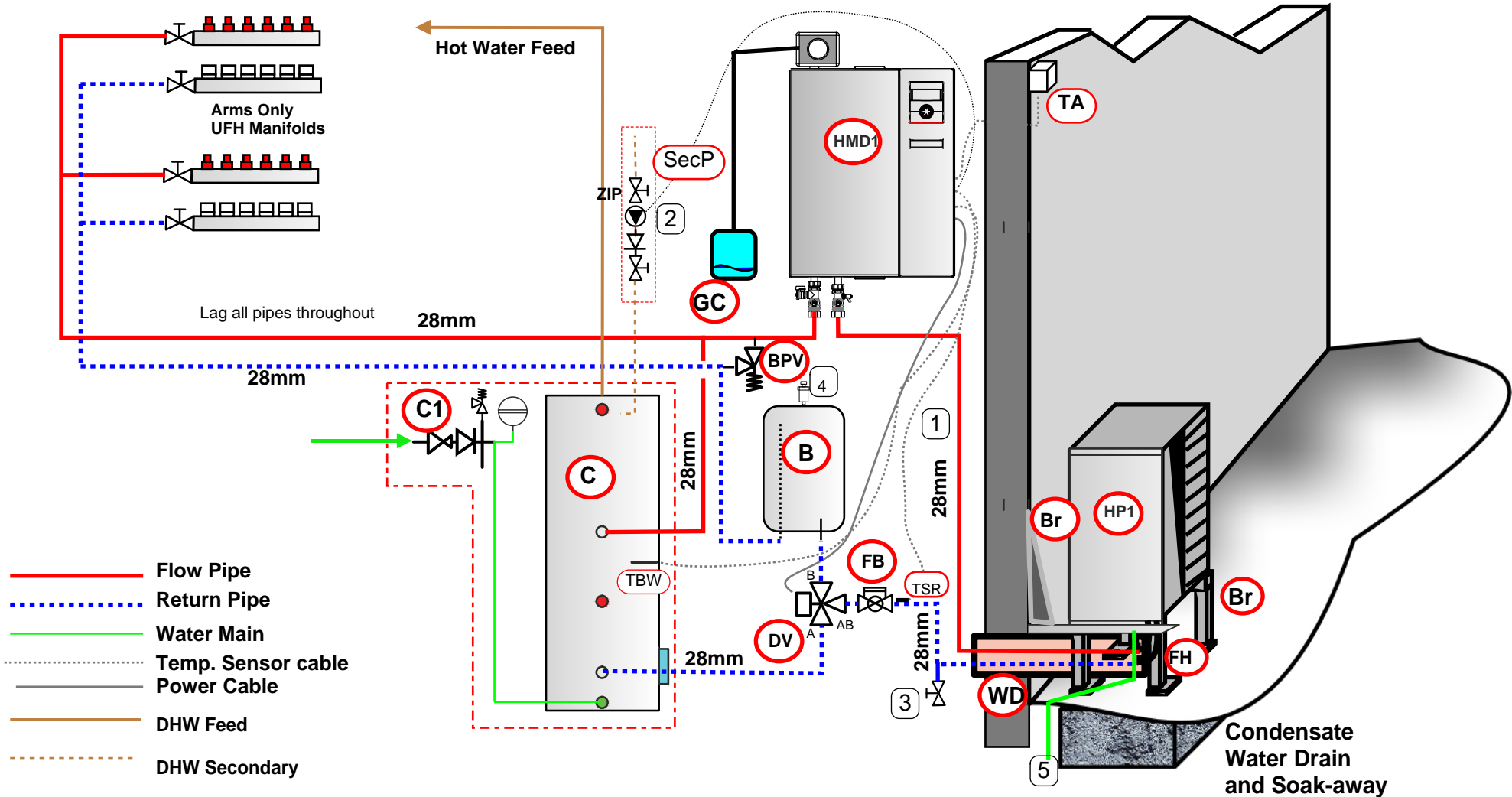

See page 3 for details of supply and installation

After flushing and cleaning the system must be filled with antifreeze mixture with protection to -10degC. The use of propylene glycol mixed with de-mineralised water is highly recommended and is included in the options portion of our quotations.

Start-up Guide Hydraulic Number 102



Pack 1 - LWD50A/SX + HMD1

Drawn; WJ

IN-HP-01.4

Date; 15/04/19

E & OE

Omnie Pack 1 Installation Guide

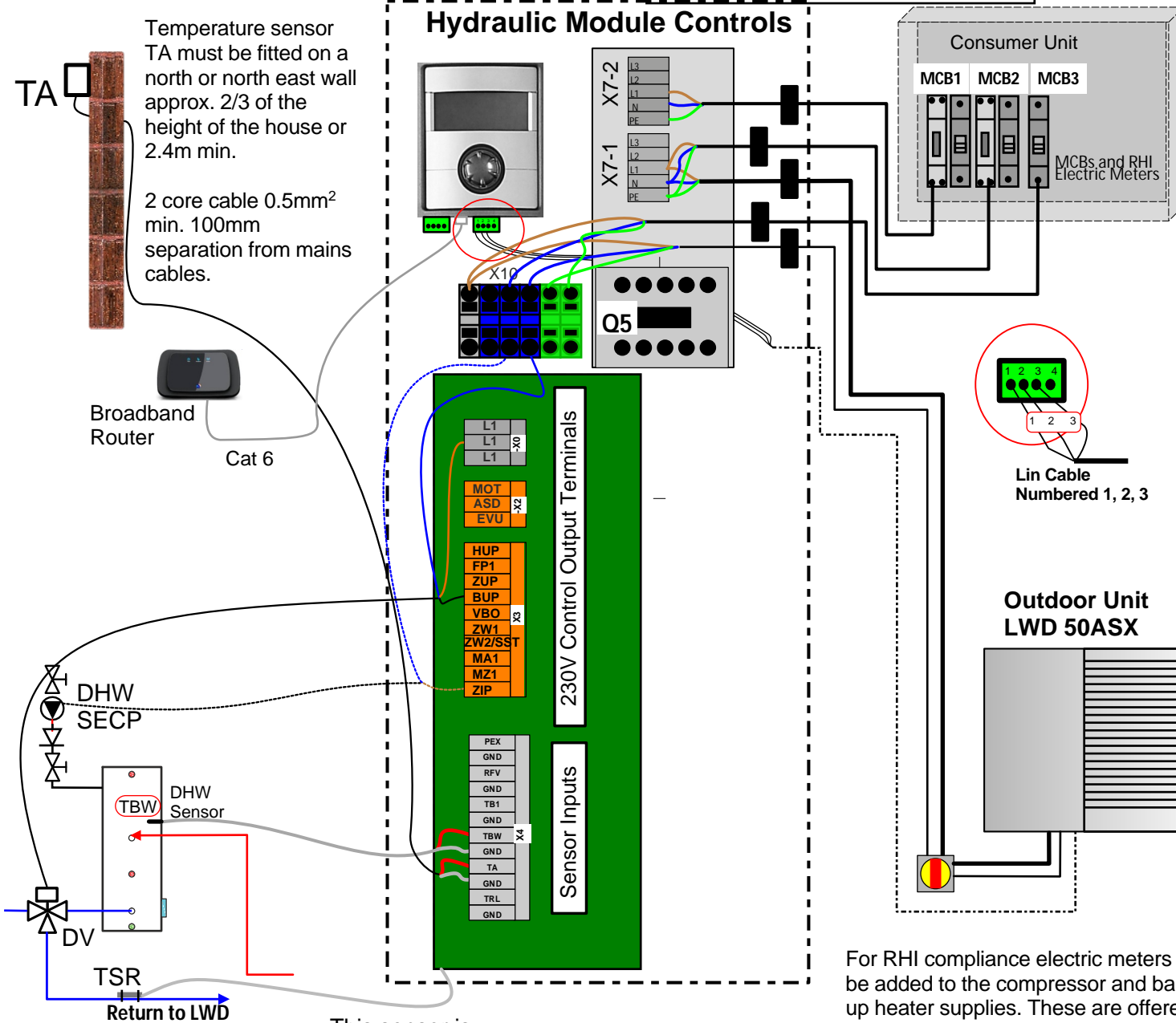

Temperature sensor TA must be fitted on a north or north east wall approx. 2/3 of the height of the house or 2.4m min.

2 core cable 0.5mm² min. 100mm separation from mains cables.

Broadband Router

Cat 6

Legend

Consumer Unit

- MCB1 Back up Heater MCB 32A Type B
- MCB2 Compressor 1 MCB 16A Type C
- MCB3 Control Circuit MCB 16A Type B

Power Terminal Blocks

- X7-1 HP1 Compressor Supply 230V 14A
- X7-2 Back up Heater Supply 230V 26A
- X10 - Controls Supply 230V 230V 16A

230V Control Output Terminals

- ZIP - DHW SecP 230V 0.5A
- BUP - DV Diverter Valve SW live 230V 0.5A

Sensor Input Terminals

- TA/GND - Outdoor Temp. Sensor
- TBW/GND - DHW Cylinder Temp.

Remote Monitoring

Include a Cat 6 Ethernet cable to the Broadband Router for connection to the remote server.

Note

All sensor cables must be kept away from mains cables with minimum separation 100mm. Sensor cables can be extended up to 25m using 0.5mm² 2 core flex.

YSLYSY cable is suitable for extending the LIN cable up to 25m. use 0.75mm² min 3 core. connect the sheath to the screen at the heat pump and to the HMD. Encase the junction in a metal box and prevent water ingress.



Pack 1 - LWD50A/SX + HMD1

Drawn; WJ

IN-HP-01.4

Date; 15/04/19

E & OE

For RHI compliance electric meters must be added to the compressor and back-up heater supplies. These are offered as separate items by Omnie but must be fitted for MCS certification.

This sensor is pre-wired on HMD

Omnie Pack 1 Installation Guide

System Components

Items Included in the Pack

HP1 - Outdoor Heat Pump unit	1 x LWD 50A/SX
HMD - Hydraulic Module	1 x HMD
B - Buffer Tank	1 x WPS61 + 2 x 1" reducers
TA - Outdoor Temperature Sensor	1 x Included in HMD
BPV - By-Pass Valve 3/4"	1 x UVD3/4"
Br- Wall/Floor Mountings (Pair)	1 Pair (Choose)
DV - 3 port Diverter Valve	1 x USV1" (28mm)
FH - Flexible Hoses 1"	1 x IPW1"
C - DHW Cylinder Inc. Group Set C1	1 x TIM xxx
FB - Strainer Isolation Valve	1 x Filterball LKK522-1" f

Essential items listed in Quote Options - available from Omnie or by others

WD - Wall Duct	1 x WDF (Wall Penetration Kit)
GC - Glycol Catcher	1 x SOL-DCVS

Essential Items to be Supplied By Others

- 1 - All interconnecting Pipe, fittings, clips and insulation
- 2 - DHW Secondary Return Pump (ZIP)
- 3 - Drain Valve ¾ BSP
- 4 - Auto Vent
- 5 - Defrost Drain 40mm Pushfit

The list is not extensive, refer to the Quote or Delivery note for full details of included items.

Electrical Items/Voltage, terminals on the control PCB

Sensors

TA = Ambient/Outdoor Temperature Sensor (Low Voltage)
TSR = Temperature Sensor Return (Low Voltage)
TBW = DHW Temperature Sensor (Low Voltage)

Pumps and Valves

DV = Diverter Valve Actuation Terminal 230V
SECP = Secondary Circulation pump 230V

If extending the pre wired cables from the LWD unit use suitable cable for the conditions.

The LIN Bus cable can be extended using SY 3 core 0.75mm² Use the braid as the screen with continuity through to the HMD

Refer to the Operating Manuals for detailed information on installing the system. Each main item has it's own manual. See the main and supplementary manuals for the LWD and HMD. The set of Operating Manuals must be left with the customer.

Pipe sizes are provided for guidance only. The sizes given are for copper tube, if using an alternative material use the equivalent bore size. If the external runs are longer than 5m use the next size up. If using HDPE pipework 32mm is equal to 28m copper and is suitable up to 15m pipe run, if longer use 40mm. Avoid using elbows, pulled bends have lower pressure loss.

Maximum separation between outdoor unit and HMD is 25m pipework and cable.

All pipework must be well lagged, recommended 19mm wall thickness closed cell foam. Tape up slit pipe lagging, elbows and valves. Protect all external lagging from UV, rodent and bird damage. External lagging must be waterproof.

The pressure relief on the HMD must be run to a catchment vessel not to main drains. Glycol solution would be discharged in the event of a high pressure incident or when testing. This can be returned to the system if clean.

Enter the Hydraulic Diagram Number (102) in the Start up Guide at start-up.

Attention

This schematic is provided as a guide to the function of the heat pump system. It shows the general arrangement of the system components and is not a full system design. The installer is responsible for the final as installed design as fits the needs of the application and that the complete heating system complies with all statutory regulations and industry standards.

Isolating valves, pipe brackets, vents, filling flushing and drain points may have been omitted for clarity of function.

The safety devices shown are indicative only and the installer is responsible for ensuring that the system complies with all statutory regulations and that it functions in a safe and efficient manner.

Frost Protection and System Cleanliness are both vital to the longevity of the system. Fill the system initially with water to flush out debris and to hydraulically pressure and leak test. After disinfecting the system with biocide fill with premixed antifreeze solution. Omnie recommend a propylene glycol/demineralised water solution with inhibitors. This can be ordered from Omnie in 20ltr drums. System failures caused by scaling or freezing may invalidate the heat pump warrantee.



Pack 1 - LWD50A/SX + HMD1

Drawn; WJ

IN-HP-01.4

Date; 15/04/19

E & OE

RI-18-45-P 230V 5(45)A LCD Electric Meter Installation

For compliance with the RHI “Metering for Performance” rule electric meters must be fitted to the supplies of the heat generating devices.

The illustration shows the meters fitted in the consumer unit next to the MCBs for the load being recorded. The meters could alternatively be located in a separate box if there are no spare ways in the consumer unit. The live from the MCB should connect to terminal 1 on the meter and the live to the load to terminal 2.

All electrical wiring must be carried out by a qualified installer to BS EN 7671 latest edition. The installer must ensure that the meters and installation are safe and fit for purpose. No responsibility is accepted by Omnie for damage or injuries associated with this guide.

The meters must be labelled as should the MCBs.

The meters supplied by Omnie are rated at 45A 230V which is sufficient for all single phase heat pumps.

The meters can be connected to a remote monitoring system:- pulsed output at terminals 20-21. Find further information from the monitoring device supplier.

See also RHI and MCS guides to metering.

RI-D175-C Instructions are on the next page.

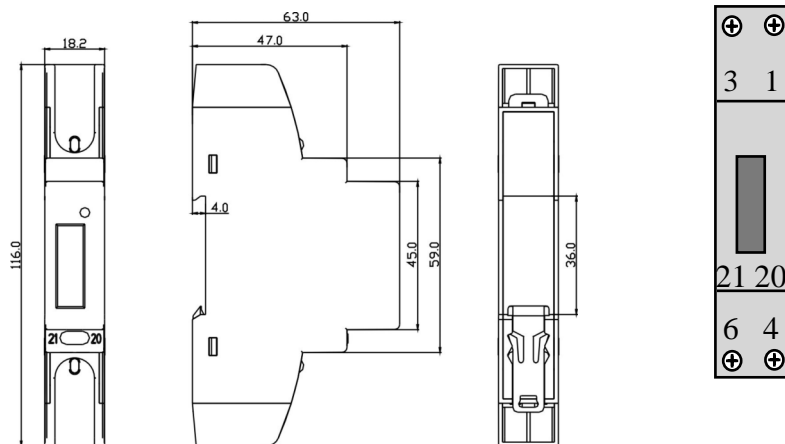
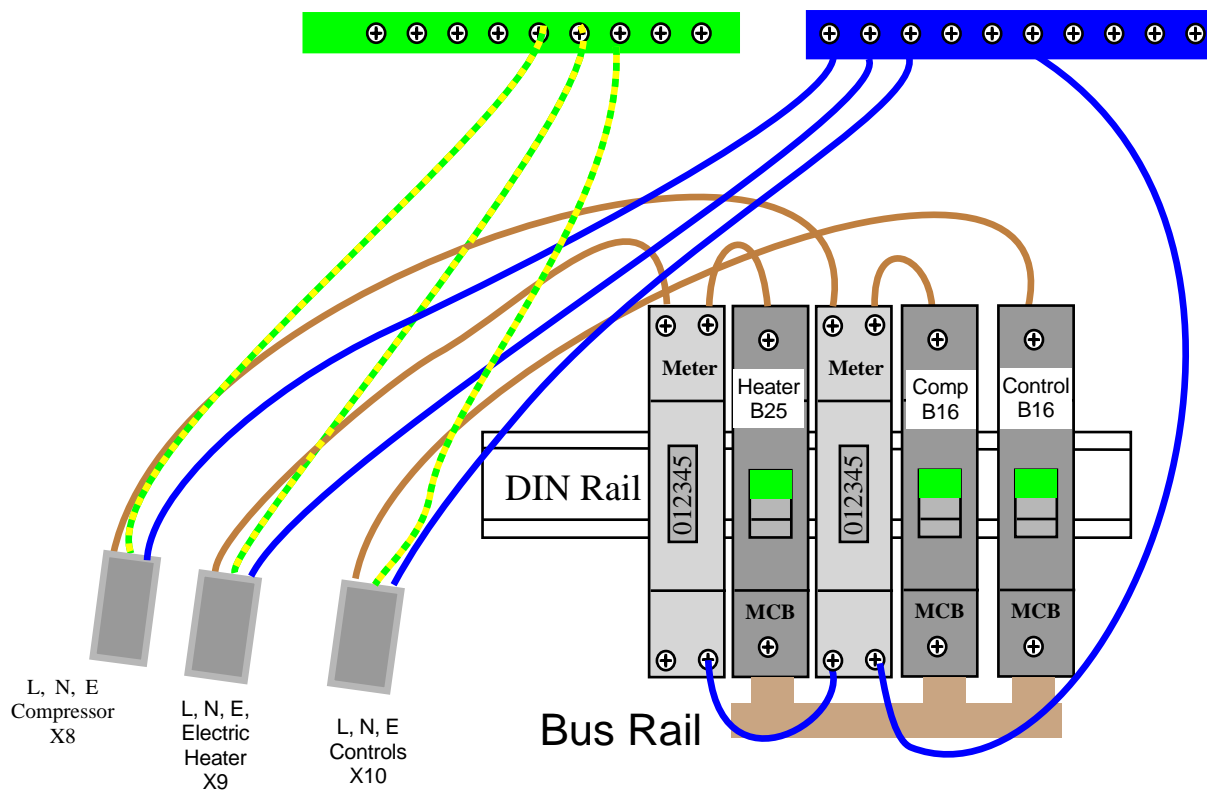

RI-18-45-P 230V 5(45)A LCD

1 Live In	3 Live Out
4 Neutral	6 Neutral
21 Pulse -	20 Pulse +



Pack 1 - LWD50A/SX + HMD1

Drawn; WJ

IN-HP-01.4

Date; 15/04/19

E. & O. E.